

## 10.3Gb/s SFP+ Transceiver

### APSPDxxHM3xDL80

#### ■ Product Features

- ✓ Supports 9.95 to 11.3Gb/s
- ✓ Duplex LC connector
- ✓ Hot-pluggable SFP footprint
- ✓ Cooled 1550nm EML laser
- ✓ RoHS compliant and Lead Free
- ✓ Up to 80Km link length
- ✓ 100GHz channel spacing
- ✓ Built-in dual CDR
- ✓ Power dissipation  
 <2.0W (0~70°C), <2.3W(0~85°C) ,  
 <2.3W(-40~85°C)
- ✓ Commercial and industrial operating temperature optional
- ✓ SFP MSA SFF-8472 SFF-8431 SFF-8432 Compliant



#### ■ Applications

- ✓ DWDM 80Km point to point link
- ✓ Fibre Channel 10G
- ✓ 10G Ethernet
- ✓ ITU-T G.698.1 DS100S1-2Dz

#### ■ General

ATOP's APSPDxxHM3xDL80 Small Form Factor Pluggable (SFP+) transceivers are compatible with SFF-8431, SFF-8432 and support 10G Ethernet ZR and 10G Fibre Channel. It is designed for use in 10G-Gigabit multi-rate links up to 80km of G.652. Digital diagnostics functions are available via a 2-wire serial interface, as specified in SFF-8472.

#### ■ Product Selection

Part Number	Operating Case temperature	DDMI
APSPDxxHM3CDL80	Commercial(0~70°C)	Yes
APSPDxxHM3EDL80	Extend(0~85°C)	Yes



# APSPDxxHM3xDL80

APSPDxxHM3IDL80	Industrial(-40~85°C)	Yes
-----------------	----------------------	-----

## ■ Product Channel Selection

Product Code	ITU channel	Frequency	Center Wavelength(nm)
APSPD61HM3xDL80	61	196.1	1528.77
APSPD60HM3xDL80	60	196.0	1529.55
APSPD59HM3xDL80	59	195.9	1530.33
APSPD58HM3xDL80	58	195.8	1531.12
APSPD57HM3xDL80	57	195.7	1531.90
APSPD56HM3xDL80	56	195.6	1532.68
APSPD55HM3xDL80	55	195.5	1533.47
APSPD54HM3xDL80	54	195.4	1534.25
APSPD53HM3xDL80	53	195.3	1535.04
APSPD52HM3xDL80	52	195.2	1535.82
APSPD51HM3xDL80	51	195.1	1536.61
APSPD50HM3xDL80	50	195.0	1537.40
APSPD49HM3xDL80	49	194.9	1538.19
APSPD48HM3xDL80	48	194.8	1538.98
APSPD47HM3xDL80	47	194.7	1539.77
APSPD46HM3xDL80	46	194.6	1540.56
APSPD45HM3xDL80	45	194.5	1541.35
APSPD44HM3xDL80	44	194.4	1542.14
APSPD43HM3xDL80	43	194.3	1542.94
APSPD42HM3xDL80	42	194.2	1543.73
APSPD41HM3xDL80	41	194.1	1544.53
APSPD40HM3xDL80	40	194.0	1545.32
APSPD39HM3xDL80	39	193.9	1546.12
APSPD38HM3xDL80	38	193.8	1546.92
APSPD37HM3xDL80	37	193.7	1547.72



# APSPDxxHM3xDL80

APSPD36HM3xDL80	36	193.6	1548.51
APSPD35HM3xDL80	35	193.5	1549.32
APSPD34HM3xDL80	34	193.4	1550.12
APSPD33HM3xDL80	33	193.3	1550.92
APSPD32HM3xDL80	32	193.2	1551.72
APSPD31HM3xDL80	31	193.1	1552.52
APSPD30HM3xDL80	30	193.0	1553.33
APSPD29HM3xDL80	29	192.9	1554.13
APSPD28HM3xDL80	28	192.8	1554.94
APSPD27HM3xDL80	27	192.7	1555.75
APSPD26HM3xDL80	26	192.6	1556.55
APSPD25HM3xDL80	25	192.5	1557.36
APSPD24HM3xDL80	24	192.4	1558.17
APSPD23HM3xDL80	23	192.3	1558.98
APSPD22HM3xDL80	22	192.2	1559.79
APSPD21HM3xDL80	21	192.1	1560.61
APSPD20HM3xDL80	20	192.0	1561.42
APSPD19HM3xDL80	19	191.9	1562.23
APSPD18HM3xDL80	18	191.8	1563.05
APSPD17HM3xDL80	17	191.7	1563.86

## Regulatory Compliance

- ESD to the Electrical PINs: compatible with MIL-STD-883 Method 3015
- ESD to the Duplex LC Receptacle: compatible with IEC 61000-4-2
- Immunity compatible with IEC 61000-4-3
- EMI compatible with FCC Part 15 Class B EN55022 Class B (CISPR 22B) VCCI Class B
- Laser Eye Safety compatible with FDA 21CFR 1040.10 and 1040.11 EN60950, EN (IEC) 60825-1,2



- RoHS compliant with RoHS 2 (2011/65/EU)。

### ■ Pin Descriptions

Pin	Symbol	Name/Description	Ref.
1	VeeT	Transmitter Ground (Common with Receiver Ground)	1
2	TX Fault	Transmitter Fault. LVTTTL-O	2
3	TX Disable	Transmitter Disable. Laser output disabled on high or open. LVTTTL-I	3
4	SDA	2-Wire Serial Interface Data Line(Same as MOD-DEF2 in INF-8074i). LVTTTL-I/O	2
5	SCL	2-Wire Serial Interface Data Line(Same as MOD-DEF2 in INF-8074i). LVTTTL-I	2
6	Mod_ABS	Module Absent, Connect to VeeT or VeeR in Module.	2
7	RS0	Rate Select 0, optionally controls SFP+ module receiver LVTTTL-I	4
8	LOS	Loss of Signal indication. Logic 0 indicates normal operation. LVTTTL-O	5
9	RS1	Rate Select 1, optionally controls SFP+ module transmitter. LVTTTL-I	4
10	VeeR	Receiver Ground (Common with Transmitter Ground)	1
11	VeeR	Receiver Ground (Common with Transmitter Ground)	1
12	RD-	Receiver Inverted DATA out. AC Coupled. CML-O	
13	RD+	Receiver Non-inverted DATA out. AC Coupled. CML-O	
14	VeeR	Receiver Ground (Common with Transmitter Ground)	1
15	VccR	Receiver Power Supply	6
16	VccT	Transmitter Power Supply	6
17	VeeT	Transmitter Ground (Common with Receiver Ground)	1
18	TD+	Transmitter Non-Inverted DATA in. AC Coupled. CML- I	
19	TD-	Transmitter Inverted DATA in. AC Coupled. CML- I	
20	VeeT	Transmitter Ground (Common with Receiver Ground)	1

**Notes:**

1. Circuit ground is internally isolated from chassis ground.
2. T\_fault is an open collector/drain output. which should be pulled up with a 4.7K – 10K Ohms resistor on the host board if intended for use. Pull up voltage should be between 2.0V to Vcc+0.3V. A high output indicates a transmitter fault caused by either the tx bias current or the tx output power exceeding the preset alarm thresholds. A low output indicates normal operation. In the low state, the output is pulled to <0.8V.
3. Laser output disabled on TX Disable >2.0V or open, enabled on TX Disable <0.8V.
4. Internally pulled down per SFF-8431 Rev4.1 .
5. LOS is open collector output. Should be pulled up with 4.7k – 10kohms on host board to a voltage between 2.0V and 3.6V. Logic 0 indicates normal operation; logic 1 indicates loss of signal.
6. Internally connected

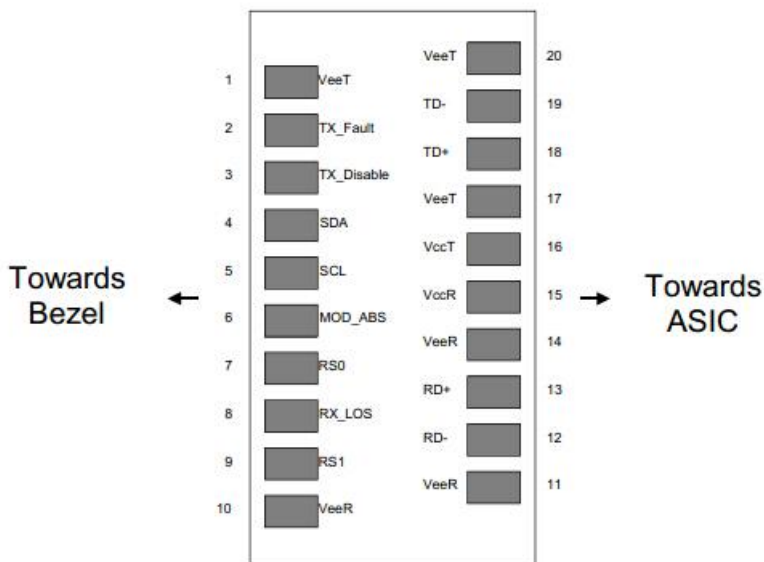

**Pin-out of Connector Block on Host Board**

■ **Recommend Circuit Schematic**

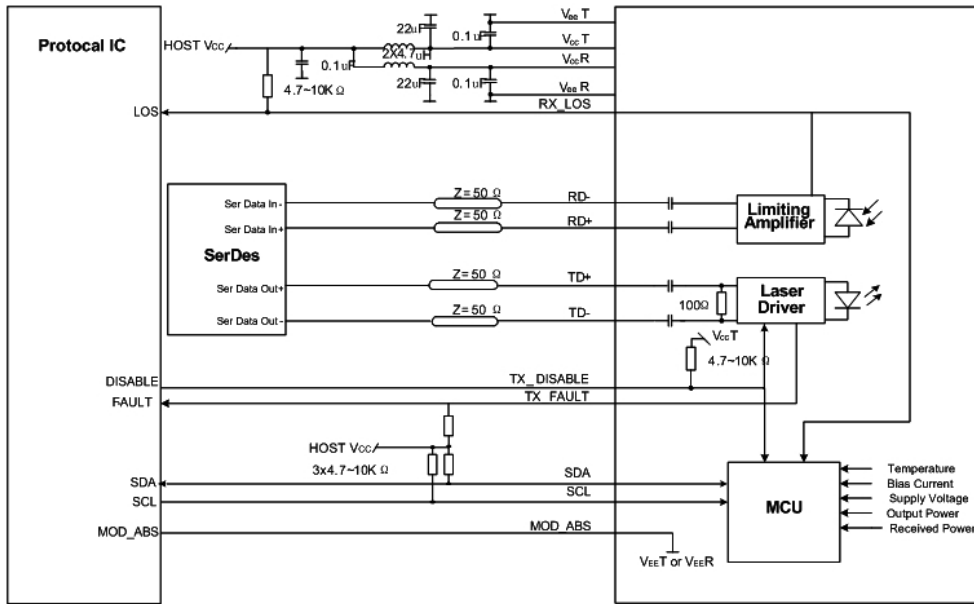

## Absolute Maximum Ratings

Parameter	Symbol	Min	Typ	Max	Unit	Ref.
Maximum Supply Voltage	Vcc	-0.5		+4.0	V	
Storage Temperature	TS	-40		+85	°C	
Operating Humidity	RH	0		85	%	

## Recommended Operating Conditions

Parameter	Symbol	Min	Typ	Max	Unit	Ref.
Power Supply Voltage	Vcc	3.13	3.30	3.47	V	
Power Supply Current	Icc			600	mA	Commercial
	Icc			700	mA	Extend
	Icc			700	mA	Industrial
Case Operating Temperature	Tc	0		+70	°C	Commercial
	Te	0		+85		Extend
	Tl	-40		+85		Industrial
Bit Rate	Br	9.95		11.3	Gbps	
9/125um G.652 SMF	Lmax			80	km	

## Electrical Characteristics (TOP=25°C, Vcc=3.3Volts)

Parameter	Symbol	Min	Typ	Max	Unit	Ref.
-----------	--------	-----	-----	-----	------	------



**APSPDxxHM3xDL80**

<b>Transmitter</b>						
Input differential impedance	Rin	80	100	120	Ω	1
Differential data input swing	Vin, pp	120		850	mV	
TX Disable-High		Vcc – 0.8		Vcc	V	
TX Disable-Low		Vee		Vee+ 0.8	V	
TX Fault-High		Vcc-0.8		Vcc	V	
TX Fault-Low		Vee		Vee+0.8	V	
<b>Receiver</b>						
Single ended data output swing	Vout, pp	300		850	mV	2
Data output rise time	Tr	30			ps	3
Data output fall time	Tf	30			ps	3
LOS-High		Vcc – 0.8		Vcc	V	
LOS-Low		Vee		Vee+0.8	V	

**Notes:**

1. AC coupled.
2. Into 100 ohm differential termination.
3. 20 – 80 %

**Optical Characteristics (TOP=25°C, Vcc=3.3 Volts)**

Parameter	Symbol	Min	Typ	Max	Unit	Ref.
<b>Transmitter</b>						
Output Opt. Power	PO	-1		4	dBm	
Optical Wavelength	λ	As per ITU-T 694.1			nm	
Side-Mode Suppression Ratio	SMSR	30			dB	
RMS Spectral Width(-20dB)	σ			1	nm	
Optical Extinction Ratio	ER	9.0			dB	
Tx Jitter(SONET)20KHZ-80MHZ	Txj1			0.3	UI	3
Tx Jitter(SONET)4MHZ-80MHZ	TXj2			0.1	UI	3
Path penalty at 1600ps/nm@9.95Gb/s				3	dB	
Relative Intensity Noise	RIN			-128	dB/Hz	



**APSPDxxHM3xDL80**

Center Wavelength	$\lambda_c$ EOL	z-100	z	Z+100	pm	
<b>Receiver</b>						
RX Sensitivity @10.3 Gb/s	SENS			-24	dBm	1,2
Receiver Overload		-7			dBm	
Optical Center Wavelength	$\lambda_C$	1260		1600	nm	
LOS De-Assert	LOSD			-28	dBm	
LOS Assert	LOSA	-37			dBm	
LOS Hysteresis	-	0.5			dB	
<b>Rx Noise-Limited Performance(OSNR)</b>						
Bit Rate(Gb/s)	Max CD (ps/nm)	BER-		Max OSNR (dB)		REF
8.5,9.95-10.3	0	1E-12	OSNR1	24	4	
	1450		OSNR2	24	4	
10.7-11.1	0	1E-4	OSNR5	18	4	
	1300		OSNR6	18	4	

**Notes:**

1. Measured with conformance signals defined in FC-PI-2 Rev. 10.0 specifications.
2. Measured with PRBS 231-1 at 10-12 BER.
3. GR-253-CORE Issue 4.
4. With optical input power at the receiver between -7 ~ -18dBm.

**■ Mechanical Specifications**

ATOP's Small Form Factor Pluggable (SFP+) transceivers are compatible with the dimensions defined by the SFP Multi-Sourcing Agreement (MSA).



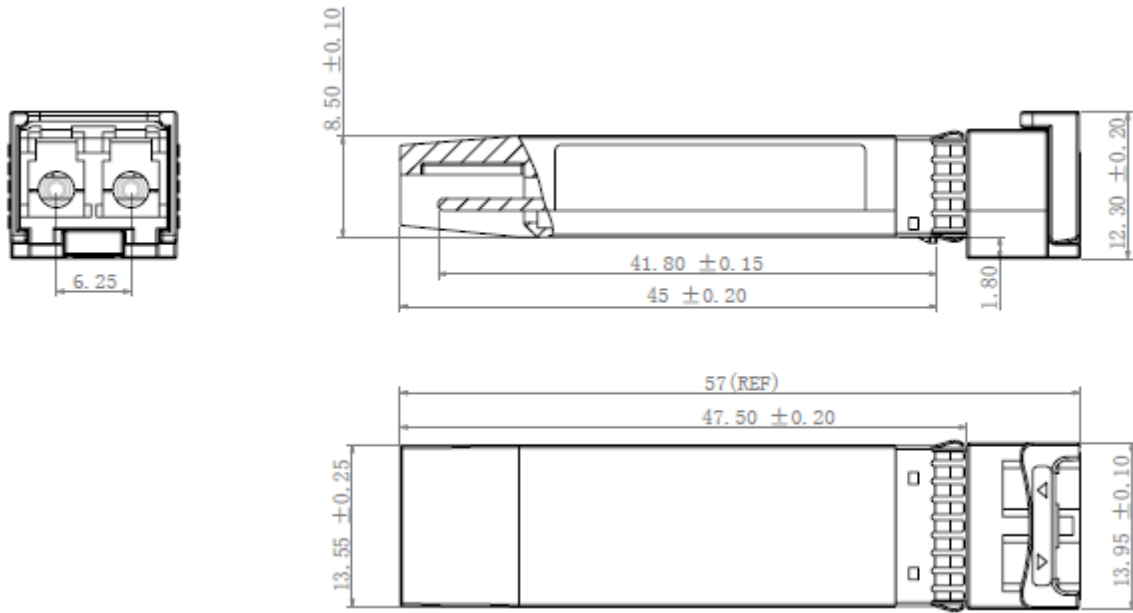

**APSPDxxHM3xDL80**

■ **EEPROM Information**

EEPROM memory map specific data field description is as below:

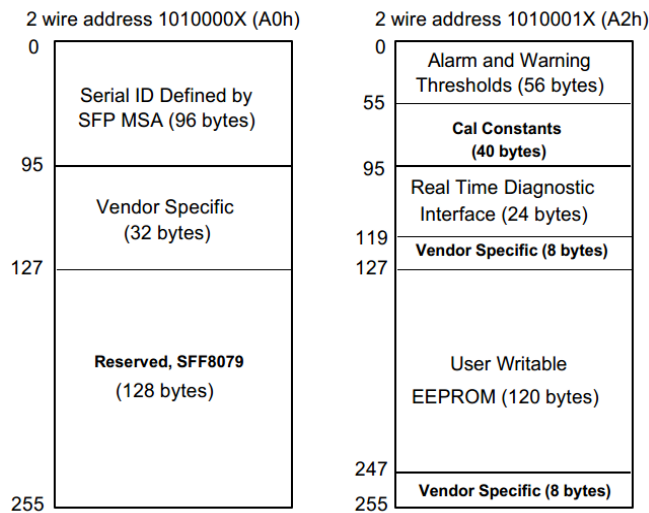

■ **Digital Diagnostic Monitoring Interface**

Five transceiver parameter values are monitored. The following table defines the monitored parameter's accuracy.

Parameter	Range	Accuracy	Calibration
-----------	-------	----------	-------------



Temperature	0 to +70°C (C)	±3°C	Internal
	0 to +85°C (E)		
	-40 to +85°C (I)		
Voltage	2.97 to 3.63V	±3%	Internal
Bias Current	0 to 100mA	±10%	Internal
TX Power	-1 to 4dBm	±3dB	Internal
RX Power	-24 to -7dBm	±3dB	Internal

■ Revision History

Revision	Initiated	Reviewed	Approved	DCN	Release Date
V1.0	xiaoaiyou	wangqiang		New Released.	July 28, 2016

■ For More Information

ATOP Corporation

Tel: +86-755-86674946

Fax: +86-755-86296723

Email: [sales@atoptechnology.com](mailto:sales@atoptechnology.com)

Web: [www.atoptechnology.com](http://www.atoptechnology.com)