

AP-B35121-3CxS3

Product Features

- Single SC receptacle optical interface compliant
- Hot-pluggable SFP footprint
- 1310nm Fabry-Perot laser transmitter
- RoHS compliant and Lead Free
- Up to 3km on 9/125
- Metal enclosure for lower EMI
- Single 3.3V power supply
- Low power dissipation <600mW
- Commercial operating temperature range: 0°C to 70°C



Applications

- 1.25Gb/s 1000Base-LX Ethernet
- 1.06 Gb/s Fibre Channel

General

ATOP's AP-B35121-3CxS3 Small Form Factor Pluggable (SFP) transceivers are compatible with the Small Form Factor Pluggable Multi-Sourcing Agreement (MSA). They simultaneously comply with Gigabit Ethernet as specified in IEEE STD 802.3 and 1x Fibre Channel as defined in FC-PI-2 Rev. 10.0 .They are RoHS compliant and lead-free.

Product Selection

AP-B35121-3CxS3

x	Blank	Without DDM
	D	With DDM

Pin Descriptions

Pin	Symbol	Name/Description	Ref.
1	VeeT	Transmitter Ground (Common with Receiver Ground)	1
2	TX Fault	Transmitter Fault. Not supported.	
3	TX Disable	Transmitter Disable. Laser output disabled on high or open.	2
4	MOD_DEF(2)	Module Definition 2. Data line for Serial ID.	3
5	MOD_DEF(1)	Module Definition 1. Clock line for Serial ID.	3
6	MOD_DEF(0)	Module Definition 0. Grounded within the module.	3
7	Rate Select	No connection required	
8	LOS	Loss of Signal indication. Logic 0 indicates normal operation.	4
9	VeeR	Receiver Ground (Common with Transmitter Ground)	1
10	VeeR	Receiver Ground (Common with Transmitter Ground)	1
11	VeeR	Receiver Ground (Common with Transmitter Ground)	1
12	RD-	Receiver Inverted DATA out. AC Coupled	
13	RD+	Receiver Non-inverted DATA out. AC Coupled	
14	VeeR	Receiver Ground (Common with Transmitter Ground)	1
15	VccR	Receiver Power Supply	
16	VccT	Transmitter Power Supply	
17	VeeT	Transmitter Ground (Common with Receiver Ground)	1
18	TD+	Transmitter Non-Inverted DATA in. AC Coupled.	
19	TD-	Transmitter Inverted DATA in. AC Coupled.	
20	VeeT	Transmitter Ground (Common with Receiver Ground)	1

Notes:

1. Circuit ground is internally isolated from chassis ground.
2. Laser output disabled on TX Disable >2.0V or open, enabled on TX Disable <0.8V.
3. Should be pulled up with 4.7k - 10kohms on host board to a voltage between 2.0V and 3.6V. MOD_DEF(0) pulls line low to indicate module is plugged in.
4. LOS is LVTTTL output. Should be pulled up with 4.7k - 10kohms on host board to a voltage between 2.0V and 3.6V. Logic 0 indicates normal operation; logic 1 indicates loss of signal.

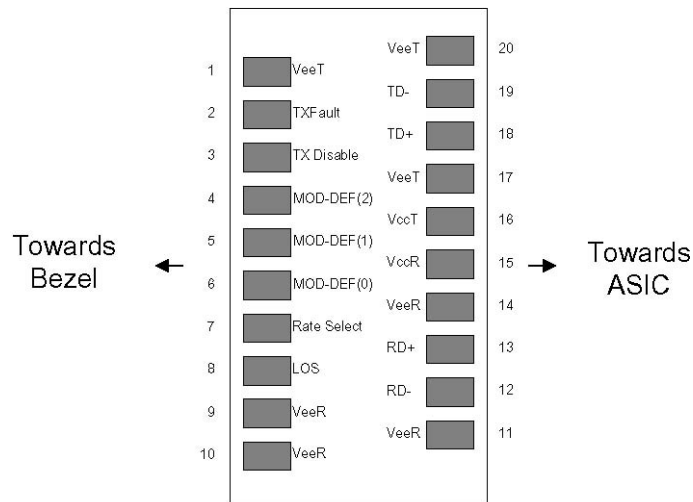

Pinout of Connector Block on Host Board

Absolute Maximum Ratings

Parameter	Symbol	Min	Typ	Max	Unit	Ref.
Maximum Supply Voltage	Vcc	-0.5		4.0	V	
Storage Temperature	TS	-40		100	°C	
Case Operating Temperature	TOP	0		70	°C	
Relative Humidity	RH	0		85	%	1

Electrical Characteristics (TOP=25°C, Vcc=3.3Volts)

Parameter	Symbol	Min	Typ	Max	Unit	Ref.
Supply Voltage	Vcc	3.00		3.60	V	
Supply Current	Icc		180	300	mA	
Transmitter						
Input differential impedance	Rin		100		Ω	2
Single ended data input swing	Vin, pp	250		1200	mV	
Transmit Disable Voltage	VD	Vcc – 1.3		Vcc	V	
Transmit Enable Voltage	VEN	Vee		Vee+ 0.8	V	
Transmit Disable Assert Time				10	us	
Receiver						
Single ended data output swing	Vout, pp	300	400	800	mV	3
Data output rise time	tr			300	ps	4
Data output fall time	tf			300	ps	4
LOS Fault	VLOS fault	Vcc – 0.5		VccHOST	V	5
LOS Normal	VLOS norm	Vee		Vee+0.5	V	5
Deterministic Jitter Contribution	RXΔDJ			80	ps	6
Total Jitter Contribution	RXΔTJ			122.4	ps	

Notes:

1. Non condensing.
2. AC coupled.
3. Into 100 ohm differential termination.
4. 20 – 80 %
5. LOS is LVTTTL. Logic 0 indicates normal operation; logic 1 indicates no signal detected.
6. Measured with DJ-free data input signal. In actual application, output DJ will be the sum of input DJ and ΔDJ.

Optical Characteristics (TOP=25°C, Vcc=3.3 Volts)

Parameter	Symbol	Min	Typ	Max	Unit	Ref.
Transmitter						
Output Opt. Power	PO	-9		-3	dBm	1
Optical Wavelength	λ	1270		1360	nm	2
Spectral Width	σ			3	nm	2
Optical Modulation Amplitude	OMA	174			μW	2,3
Optical Rise/Fall Time	tr/tf		170	260	ps	4
Deterministic Jitter Contribution	TXΔDJ		20	56.5	ps	5
Total Jitter Contribution	TXΔTJ		50	119	ps	
Optical Extinction Ratio	ER	9			dB	
Receiver						

Average Rx Sensitivity @ 1.25 Gb/s (Gigabit Ethernet)	RSENS2			-23	dBm	6, 7
Average Rx Sensitivity @ 1.06 Gb/s (1X Fibre Channel)	RSENS1			-24	dBm	6, 7
Maximum Received Power	RXMAX	-2			dBm	
Optical Center Wavelength	λ_C	1480		1620	nm	
LOS De-Assert	LOSD			-25	dBm	
LOS Assert	LOSA	-36			dBm	
LOS Hysteresis		0.5			dB	

Notes:

1. Class 1 Laser Safety.
2. Also specified to meet curves in FC-PI-2 Rev. 10.0 Figure 18, which allow trade-off between wavelength, spectral width and OMA.
3. Equivalent extinction ratio specification for Fibre Channel. Allows smaller ER at higher average power.
4. Unfiltered, 20-80%. Complies with IEEE 802.3 (Gig. E) and FC 1x eye masks when filtered.
5. Measured with DJ-free data input signal .In actual application, output DJ will be the sum of input DJ and ΔDJ .
6. Measured with conformance signals defined in FC-PI-2 Rev. 10.0 specifications.
7. Measured with PRBS 2⁷-1 at 10⁻¹² BER .

General Specifications

Parameter	Symbol	Min	Typ	Max	Units	Ref.
Data Rate	BR	1062		1250	Mb/sec	1
Bit Error Rate	BER			10 ⁻¹²		2
Max. Supported Link Length on 9/125 μ m SMF @ 1x Fibre Channel	LMAX1		20		km	3, 4
Max. Supported Link Length on 9/125 μ m SMF @ Gigabit Ethernet	LMAX2		20		km	3, 4

Notes:

1. Gigabit Ethernet and 1x Fibre Channel compliant.
2. Tested with a PRBS 2⁷-1 data pattern.
3. Dispersion limited per FC-PI-2 Rev. 10
4. Attenuation of 0.55 dB/km is used for the link length calculations. Please refer to the Optical Specifications in Table IV to calculate a more accurate link budget based on specific conditions in your application.

Environmental Specifications

ATOP Commercial Temperature BIDI SFP transceivers have an operating temperature range from 0°C to +70°C case temperature.

Parameter	Symbol	Min	Typ	Max	Units	Ref.
-----------	--------	-----	-----	-----	-------	------

Case Operating Temperature	Top	0		70	°C	
Storage Temperature	Tsto	-40		100	°C	

Mechanical Specifications

ATOP's Small Form Factor Pluggable (SFP) transceivers are compatible with the dimensions defined by the SFP Multi-Sourcing Agreement (MSA).

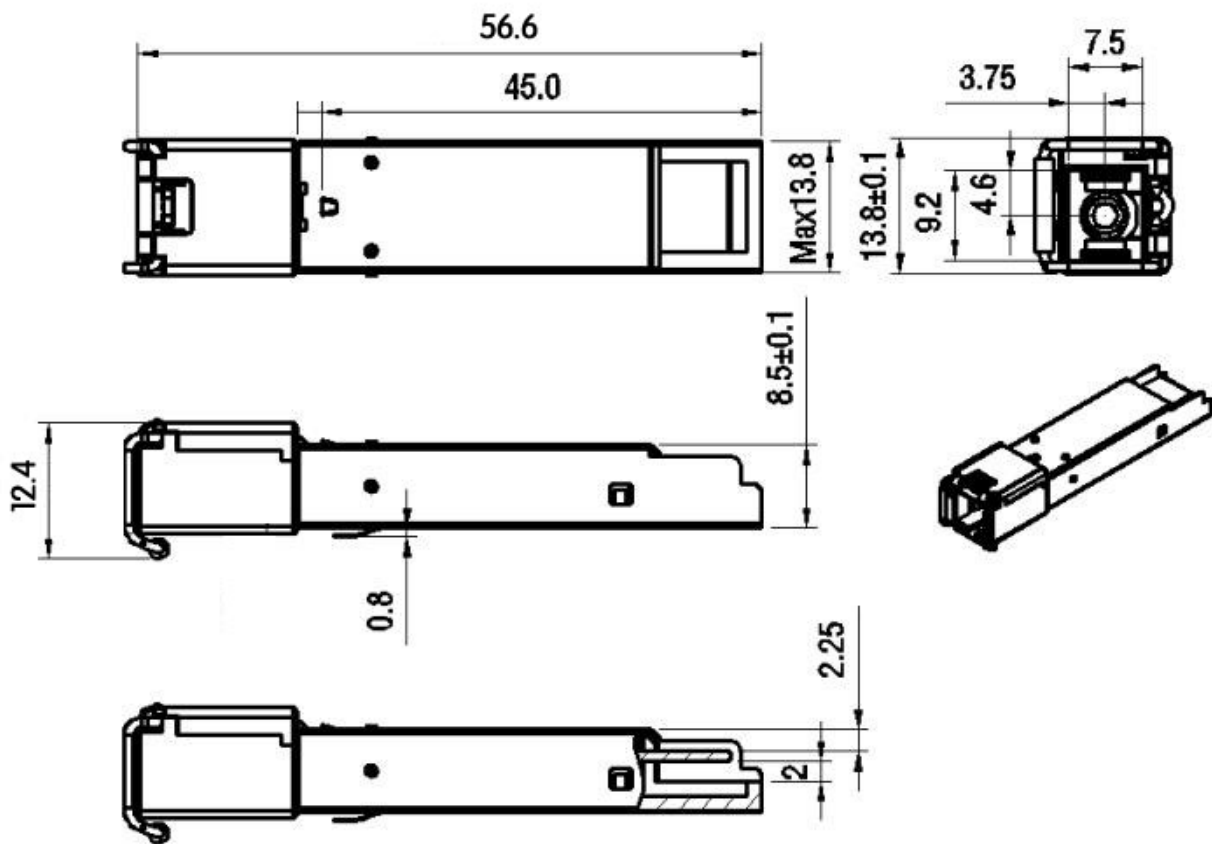

AP-B35121-3CxS3

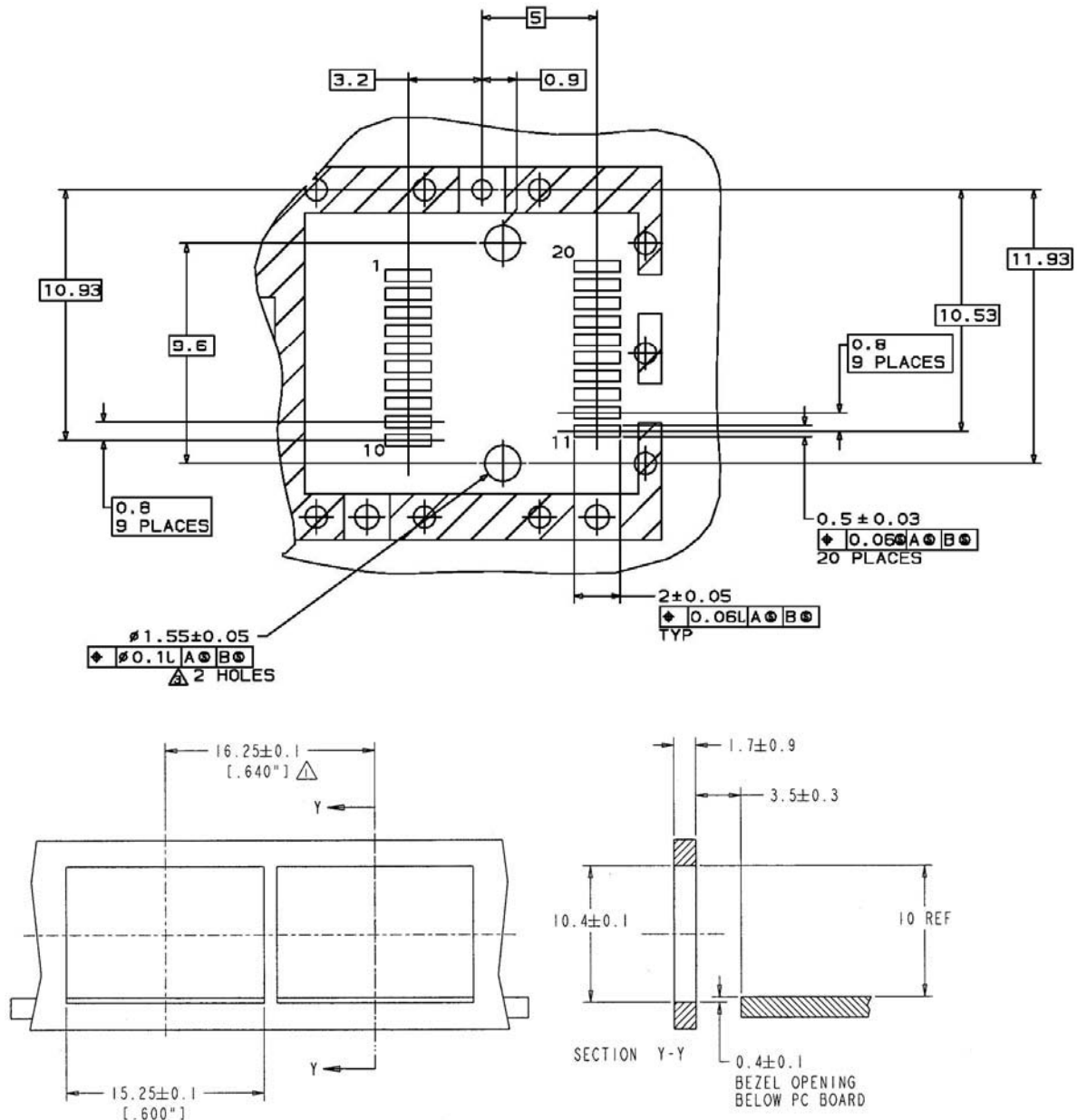

NOTES:

△ MINIMUM PITCH ILLUSTRATED, ENGLISH DIMENSIONS ARE FOR REFERENCE ONLY

2. NOT RECOMMENDED FOR PCI EXPANSION CARD APPLICATIONS

For More Information

ATOP Technology co., Ltd
 5/F, No.1 Building, Yuanzheng industrial park, North of Wuhe Av.
 Longgang District, Shenzhen, China.
 Tel: +86-755-83461686 83461606 83461650
 Fax: +86-755-83461640
 Email: sales@atoptechnology.com
 Web: www.atoptechnology.com